

# Extended Receiver Calibrations in MS462xx VNAs

Scorpion®

## Introduction

With Scorpion version 2.01 system firmware, a new expanded receiver calibration is available that can help with a variety of measurements. The changes are primarily in ways to increase flexibility in how the calibrations are performed and how they are used. These shifts could have benefits in the following applications:

- Extended frequency range measurements in which an external converter is used to bring the signal back into Scorpion's frequency range. Now the receiver calibration can be performed and used at the input of this external converter.
- Complex frequency conversion measurements (including multipliers and integrated systems). Now the receiver cal can track which frequency range is being used during different parts of the measurement and properly correct at each stage.
- Situations where an external source is needed to perform the receiver cal (primarily in extended frequency range situations, but also in some logistically challenging environments).
- Measurement of DUTs with IFs to 10 kHz using Scorpion Option SM6186 that allows more advanced handling of receiver calibrations.

This flexibility is implemented primarily through two changes to the user interface: an additional intelligent equation in multiple source control (for information on the use of standard multiple source control, see the application note "Multiple Source Mode," Anritsu part number 11410-00244) and a text file interface for receiver calibrations when complex processing is needed. The use of these features is discussed in the following sections.

```

- BAND 1 DEFINITION SUMMARY -
DISPLAYED FREQUENCY RANGE
BAND START F          BAND STOP F
13.000000000 GHz      15.000000000 GHz

SYSTEM EQUATIONS
FREQUENCY = (MULTIPLIER/DIVISOR) * (F+OFFSET FREQ)

SOURCE 1 = (1/1) * (F-12.000000000 GHz)
SOURCE 2 = (1/1) * (F-11.993000000 GHz)
SOURCE 3 = (1/1) * (12.000000000 GHz C.W.)
SOURCE 4 = (1/1) * (F+0.000000000 MHz)
RECEIVER = (1/1) * (F-12.000000000 GHz)
RCVR SRC = (1/1) * (F+0.000000000 MHz)

- INSTRUCTIONS -
1. SET BAND FREQUENCIES. EXCEPT FOR BAND 1, ALL
   START FREQS FOLLOW PREVIOUS BAND'S STOP FREQ.
   EDIT SOURCE 1 THRU 4, RECEIVER EQUATIONS AND
   RCVR SOURCE, THEN SELECT <STORE BAND>.
2. ALTERATIONS TO A BAND'S DEFINITION PLACE THE
   MULTIPLE SOURCE MODE IN THE DEFINE STATE.
   IF A BAND IS ALTERED, IT AND ANY DESIRED BAND
   FOLLOWING IT NEED TO BE STORED AGAIN.

DEFINE BANDS
▶ BAND 1
BAND START FREQ
13.000000000 GHz
BAND STOP FREQ
15.000000000 GHz
EDIT SYSTEM
EQUATIONS
STORE BAND 1
BANDS STORED:
(1 )
CLEAR ALL
DEFINITIONS

RETURN

```

Figure 1. The multiple source definition screen shows the new RCVR SRC equation that defines the receiver calibration reference plane.

## Multiple source control

An equation, labeled RCVR SRC, has been added to the multiple source tableau as shown in Figure 1. Its job is to inform the system what frequency should be used to index the receiver calibration vector during calibrations or measurements. Said another way, this equation describes where the reference plane is (in terms of frequency range) for the receiver calibration. This new equation is present in transmission/reflection, IMD and harmonics modes.

## Explanation of equations, calibrations and measurements

Much like the extended noise source equation when in noise figure mode, this equation tells the system where to reference the receiver cal frequency during both calibration and measurement. It is not restricted to the hardware range of the instrument since it may be referencing, for example, a high frequency mixer input. This is the case in the Figure 1 example; the setup being measured is shown in Figure 2.

In this case, the DUT is an upconverter with a fixed LO of 12 GHz. The input ranges from 1-3 GHz and output from 13-15 GHz. We wish to use an external mixer to reconvert this output back into the Scorpion's frequency range using another 12 GHz mix (the two LOs need not be the same, it was done in this example for convenience and noise minimization; other combinations may be desirable for isolation or other practical reasons).

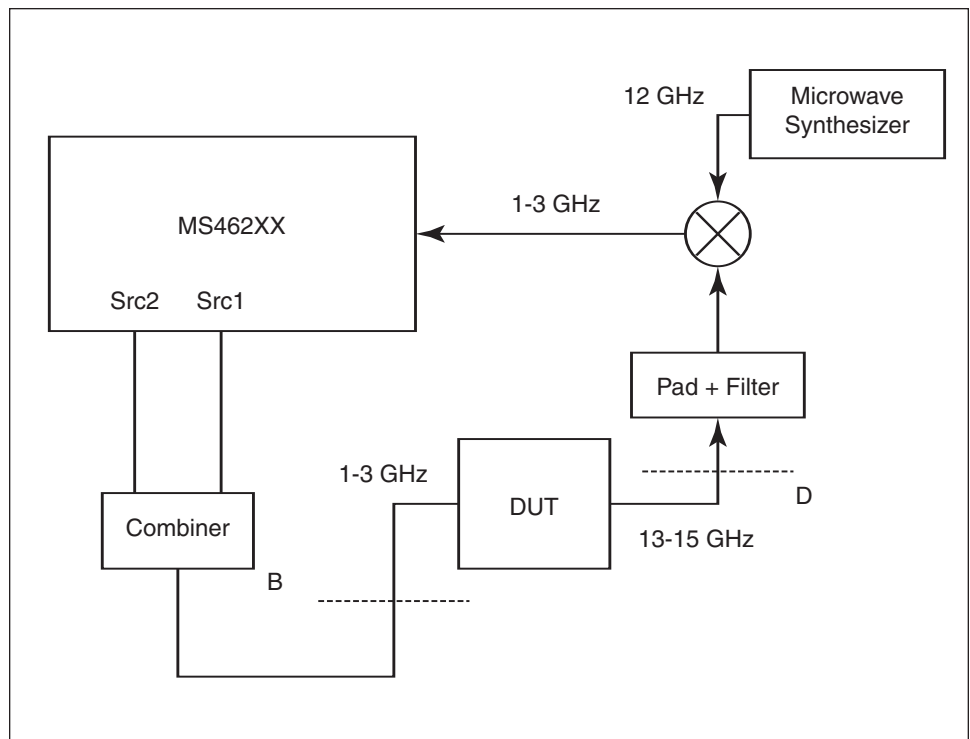

Figure 2. The measurement corresponding to the multiple source setup of Figure 1 is shown here.

The key to this measurement is to calibrate to form absolute power planes (connections where we will know precisely what 0 dBm, or some other convenient level, looks like). The key planes in this setup are obviously D (the DUT output) and B (the DUT input). The calibration at plane D is an aptly named receiver calibration.

We wish to perform and use the receiver cal in the 13-15 GHz range at plane D; thus the RCVR SRC equation is set equal to the runner variable  $f$ . Source 1 (the main internal Scorpion source) is sweeping over 1-3 GHz and source 2 is offset from source 1 by 7 MHz (it is only used here for IMD measurements). Note that one may want to perform a broadband receiver calibration (1-15 GHz for this example) to enable simpler conversion loss/gain measurements. In this case, a flat power calibration could be performed at plane B and the multiple source equations modified to allow some conversion in the 1-3 GHz range. Then the receiver calibration can encompass the low frequency range and a plane B-plane D connection can be used to normalize against the input to the DUT.

## Receiver cals using external synthesizers

When performing the receiver calibration using the external synthesizer, some points must be considered:

- A flat power cal may need to be done at the end of the cable connected to the synthesizer (this is often termed a user cal in the synthesizer parlance). This user cal should be activated prior to performing the receiver calibration. If this process is to be performed over GPIB from an external computer, the pass-through capability of the Scorpion may be used to send commands directly from the computer to the synthesizer. Some care may be required to avoid multiple controller conflicts on the GPIB bus.
- The system uses source 1 power to determine the power level that is used during the receiver calibration (default 0 dBm). If a different power level is used with the external synthesizer; source 1 power should be modified to match it. This may seem awkward but the source used to perform the receiver calibration could be derived from multiple synthesizers or included embedded networks.
- It is assumed that an Anritsu synthesizer under multiple source control is used to perform this receiver cal but there are certain step-by-step procedures that can be used with manually controlled synthesizers. Consult the factory for more information.

# Measurement example: Upconverter

Measurements were performed conforming to the above setup. Of interest was a measurement of conversion loss of the DUT (upconverter) as well as IMD. To perform this measurement, the following tasks were needed:

- Flat power calibration of the synthesizer over 13-15 GHz (for use at PLANE D)
- Receiver calibration at the input of the external mixer assembly (at 0 dBm in this case, acceptable because of the high linearity of this assembly) from 13-15 GHz (PLANE D)
- Optional use of the synthesizer to perform RF normalization based on the desired input power level (only needed if not 0 dBm)
- Flat power calibration of the Scorpion source (at the output of the combiner, PLANE B)
- Measurement of b2/1 as conversion loss

Note that the power of the RCVR SRC equation in multiple source control is that the receiver calibration can now be decoupled from the physical Scorpion receiver. Results are shown in Figure 3.

The results are within expectations. Some of the ripple is due to uncorrected mismatch which could be handled with additional padding or one port match correction techniques.

An IMD measurement was also desired, both at a 14 GHz DUT CW output and swept over most of the frequency range. A flat power calibration of source 2 was performed in addition to the steps above (also at the combiner output). Both tones were set to about -7 dBm and the results are shown in Figure 4.

These results also met expectations for this class of DUT.

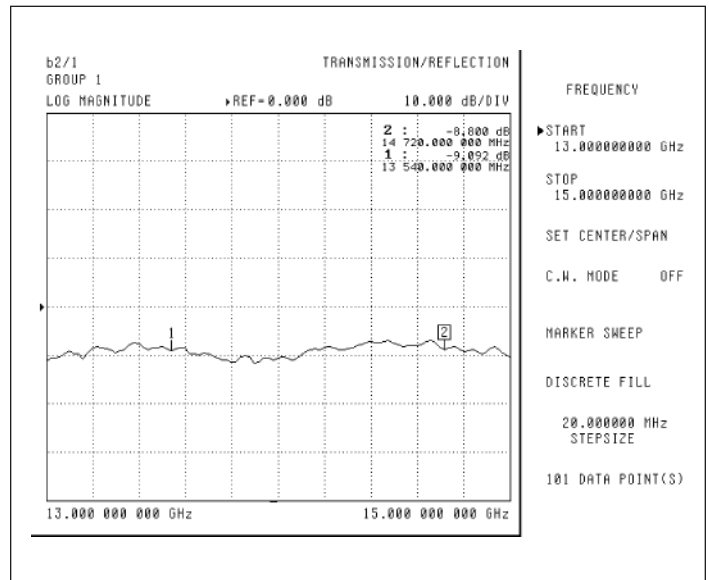

Figure 3. A conversion loss measurement of a DUT using the setup of Figure 1 is shown here.

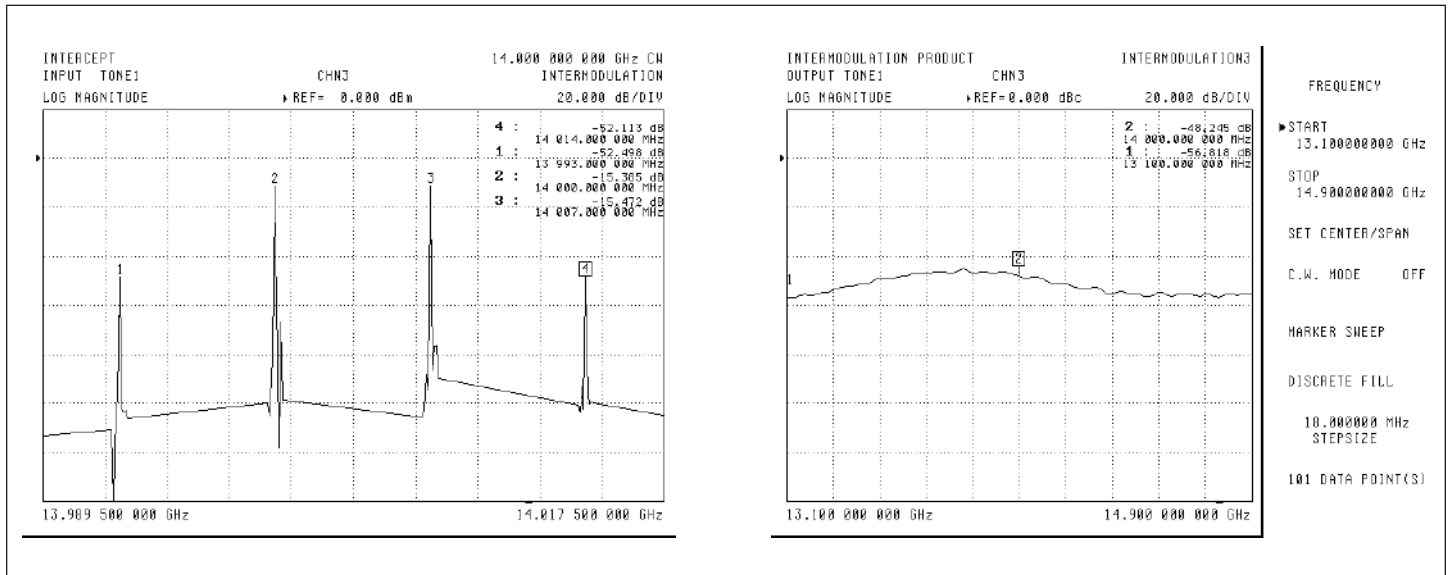

Figure 4. The CW and swept IMD of the example DUT are shown here. The two Scorpion sources provided the input tones (7 MHz offset).

## Measurement example: Shunt Schottky diode

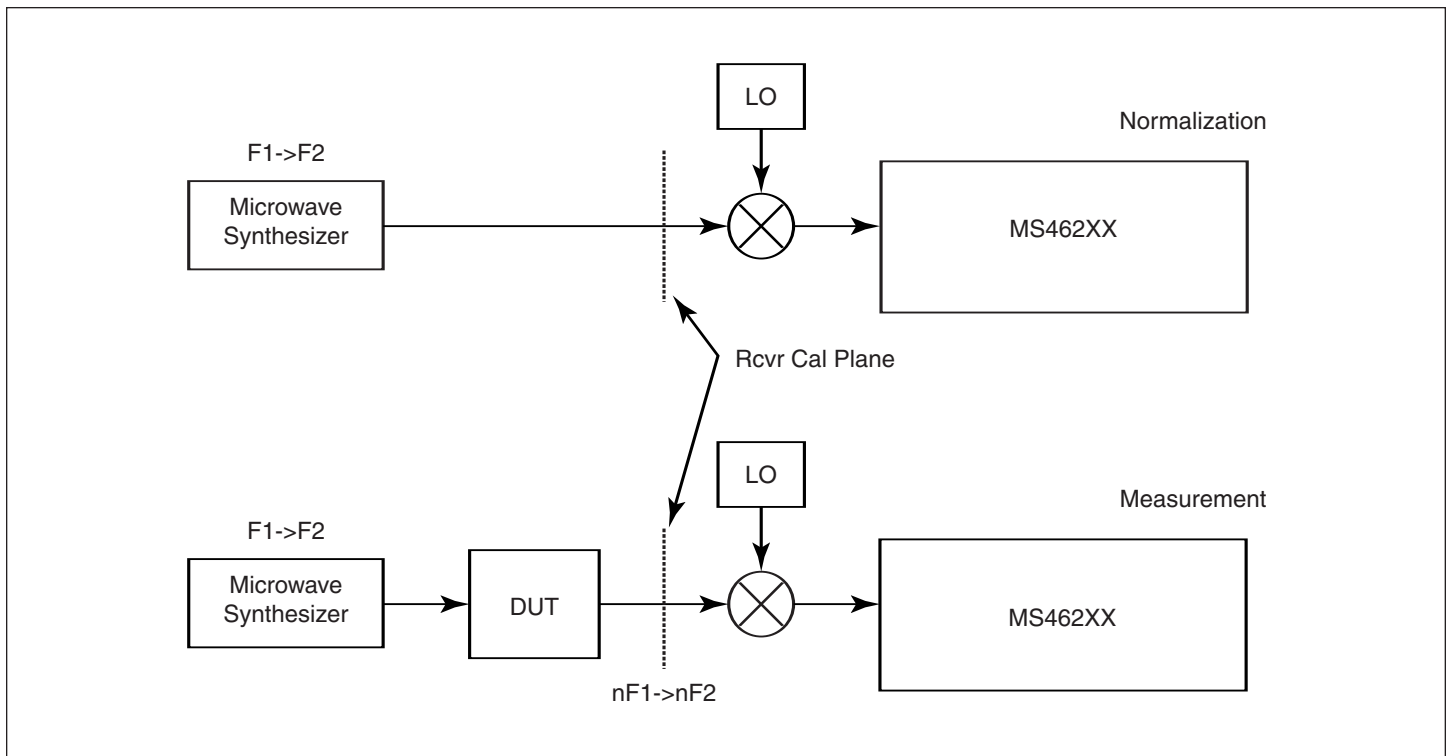

Figure 5. The normalization and measurement processes for a harmonic (multiplier) measurement are shown here. During the normalization process, the RCVR SRC equation is indexing in the frequency range  $F1 \rightarrow F2$ . During the measurement process, it is indexing in the range  $nF1 \rightarrow nF2$  where  $n$  is the harmonic of interest.

For a slightly different example, the relative harmonic output of a shunt Schottky diode was measured. The more challenging aspect of this measurement is that the input power normalization must be measured with the receiver calibration indexing over the fundamental frequency range while the output harmonic measurement must be performed with the receiver calibration indexing over the harmonic frequency range. If using an external converter, the RCVR SRC equation must be dynamically changed to ensure the use of the correct index. The process is illustrated in Figure 5.

The measurement results for this simple structure are shown in Figure 6. Again the results were within expectations.

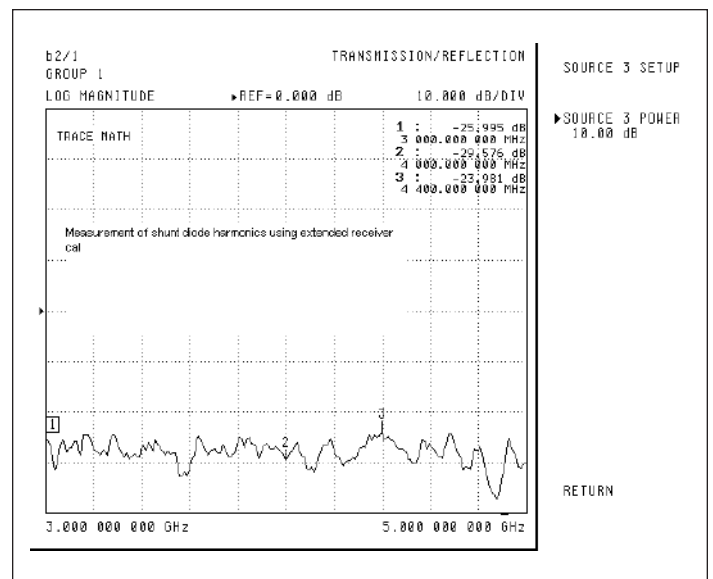

Figure 6. The 2nd harmonic output of a shunt diode is plotted here. The RCVR SRC equation was used during normalization (note the TRACE MATH indicator) and measurement to ensure that the receiver calibration was always indexing in the correct frequency ranges.

## Text-based receiver cal entry

Another change is the added ability to enter the receiver calibration data using a text file (in addition to the usual ability to generate that data via a standard calibration). This may be of value when an uncontrolled source needs to be used to perform the receiver cal (due to frequency range or equipment availability). Examples include:

- The low frequency converter option discussed in the appendix of this document. Here a factory-characterized reconverter internal to the Scorpion is used to allow the measurement of DUT output frequencies as low as a few kHz. The characterization (which may be repeated by the user) is implemented using this text file protocol.
- An external converter assembly is measured separately elsewhere and it is inconvenient to perform the receiver cal again on the instrument to be used. A text file can be saved and then recalled on any Scorpion on which the measurement is to be performed.

The menus for performing these tasks are shown in Figure 7.

## Viewing receiver cals

Along with the previously-available choices of which ports were being calibrated, the new menu allows the user to view the current calibration file vs. frequency (DISPLAY RECEIVER CAL TABLE), load or save the file from or to disk, and clear the receiver calibration. Some important things to note about the use of these files:

- The text-entry and performed-cal data coexist with sorting done by frequency. If a calibration is performed at some of the same frequencies as a previously-loaded text file, the measured data will take precedence (thus removing a dependence on the order in which operations are performed).
- Receiver calibration data is non-volatile but may be cleared with a default-0.
- There are no limits on the frequencies that can be used in the text file (other than that they are positive). The data points will only play a role in a measurement if those frequency indices are accessed via the receiver frequency or the RCVR SRC equation (within multiple source control).
- The total number of points that can exist in the receiver cal is 1601 (whether from manual calibrations, text file loading, or both). New points will not be loaded if there would be an overflow. The loaded text file can have a maximum of 101 points.

To illustrate the simple task of displaying the current receiver cal file, consider the calibration done in the first part of the document. The first page of that file is shown in Figure 8. Other parts of the file can be viewed using NEXT PAGE and PREVIOUS PAGE. When applying the cal, linear interpolation is used between frequency points. The cal will be turned off if frequencies outside of its range would be needed to apply the calibration.

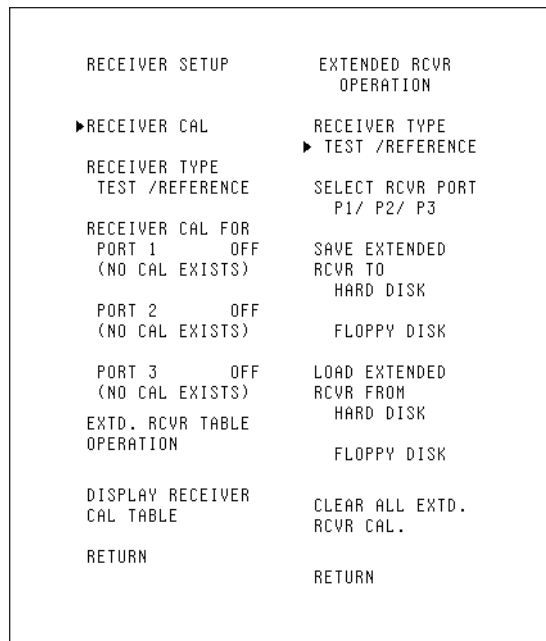

Figure 7. The menus related to text entry of receiver cal data are shown here.

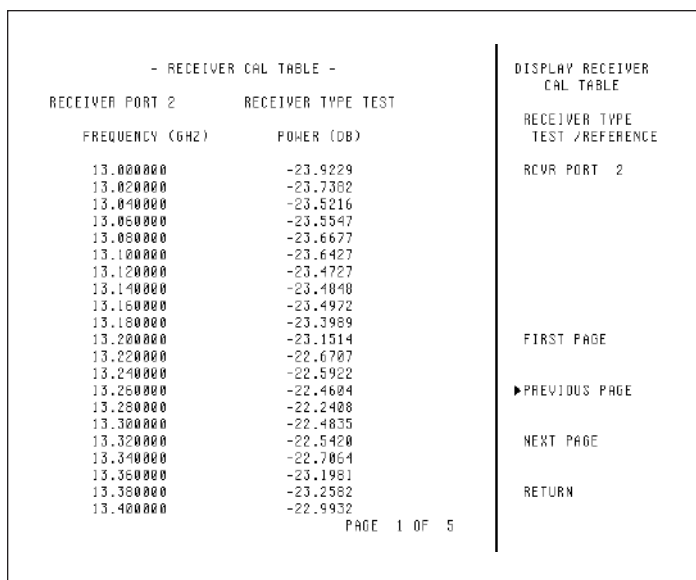

Figure 8. An example receiver cal pertaining to the setup of Figure 1 is shown here. This particular example file has 600 points and would be viewed on multiple pages.

# Combining receiver cal files

An example of the combining process is shown in Figures 9 and 10. A manual receiver cal was first done starting at 10 MHz. Then a text file receiver cal was loaded that started at 1 kHz and ran to 3 MHz. Since there was no overlap between these files, they were simply concatenated. The values in the text file are artificial but they allow one to clearly see the combining process.

Some examples using this file concept are contained in the appendix along with the discussion of the reconverter for measuring DUTs with low frequency IFs.

```

- RECEIVER CAL TABLE -
RECEIVER PORT 2      RECEIVER TYPE TEST
FREQUENCY (GHZ)      POWER (DB)
0.010000             -8.5931
0.032475             -8.3166
0.054950             -8.4283
0.077425             -9.1297
0.099900             -9.3272
0.122375             -9.2375
0.144850             -9.2300
0.167325             -9.5520
0.189800             -9.8471
0.212275             -10.0275
0.234750             -9.7436
0.257225             -9.3816
0.279700             -9.1326
0.302175             -9.1882
0.324650             -9.1160
0.347125             -9.0843
0.369600             -9.2116
0.392075             -9.3475
0.414550             -9.4864
0.437025             -9.6832
0.459500             -9.6518
PAGE 1 OF 17
    
```

Figure 9. An initial manual receiver cal is shown here; it starts at 10 MHz.

```

- RECEIVER CAL TABLE -
RECEIVER PORT 2      RECEIVER TYPE TEST
FREQUENCY (GHZ)      POWER (DB)
0.000001             -20.0000
0.000010             -15.0000
0.000100             -10.0000
0.001000             -5.0000
0.003000             0.0000
0.010000             -8.5931
0.032475             -8.3166
0.054950             -8.4283
0.077425             -9.1297
0.099900             -9.3272
0.122375             -9.2375
0.144850             -9.2300
0.167325             -9.5520
0.189800             -9.8471
0.212275             -10.0275
0.234750             -9.7436
0.257225             -9.3816
0.279700             -9.1326
0.302175             -9.1882
0.324650             -9.1160
0.347125             -9.0843
PAGE 1 OF 17
    
```

Figure 10. A combined file is shown here. The manual cal from Figure 9 was combined with a text file whose frequency indices ran from 1 kHz to 3 MHz.

# Receiver cal file format

Users generating their own files (from a separate characterization for example) need to employ a very simple text file format. The format requires two columns (frequency and receiver level in dB), tab-delimited with a header of the form:

```
# GHZ      0.0000
```

to indicate the frequency units used in the file. The zero in the above line is the power level in dBm at which the receiver data was collected. A value other than 0 acts as an offset. That value (positive or negative in dBm) will be added to the tabular value prior to storage. Initial lines starting with an exclamation point are treated as comments and ignored. Two examples are shown below:

```

! EXAMPLE FILE
! DATE 06/12/04    16:55
! RCVR PORT 2
# MHZ      0.0000
0.010      -46.58
0.030      -36.75
0.050      -31.95
0.100      -25.73
0.300      -25.12
0.500      -26.6
1.000      -23.68
2.000      -21.35
3.000      -15.24
4.000      -12.74
6.000      -10.40
    
```

```

! SECOND EXAMPLE
! DATE 03/12/04    16:55
! RCVR PORT 2
# GHZ      7.00000
0.000001   -20.000000
0.000010   -15.000000
0.000100   -10.000000
0.001000   -5.000000
0.003000   0.000000
0.010000   5.000000
0.100000   10.000000
1.000000   15.000000
3.000000   20.000000
10.000000  25.000000
30.000000  30.000000
100.000000 35.000000
    
```

## Uncertainty impacts

For measurements that are receiver calibration based, the fundamental uncertainty is that related to that of the power calibration used to perform the flat power calibrations prior to the receiver cal. While one could argue that the desired measurement is relative, this result is based on a comparison of two different absolute power measurements, often at different frequencies. Typically, the power uncertainty will be on the order of a tenth of a dB or so depending on match levels. This will typically be the base uncertainty for factory-performed receiver calibrations under well-matched conditions.

Aside from connector repeatability, another major source of uncertainty will be mismatch between the DUT and the receiver or source (as well as from synthesizer to receiver during the receiver cal). These can be partially corrected using reflectometer data. If left uncorrected, the added uncertainty can be on the order of 0.2 to 0.3 dB for a high level transmission measurement with  $-15$  dB DUT match and a receiver match of about  $-20$  dB.

## Conclusion

Extended receiver calibration concepts have been presented that allow for easier frequency converting measurements and measurements over extended frequency ranges. The RCVR SRC equation within multiple source allows calibrations independent of the physical Scorpion receiver so external converters can be used. The text file entry of receiver calibrations allows portable characterization of converters and the use of a low frequency IF measurement special option on the instrument.

## Appendix: Converter measurements to 10 kHz and below

To allow for the measurement of converters with low IFs, as may be found in homodyne and related systems, a special option for the Scorpion (SM6186) is available that allows measurements down to 10 kHz. A reconverter is used to place incoming signals back in the frequency range of the basic receiver (3 MHz and up in this case) and the text entry receiver calibration allows accurate measurements. With this option, the system automatically activates the reconverter when the programmed receiver frequency is below 3 MHz. At higher receive frequencies, the reconverter enters a bypass state. A block diagram of one receiver path is shown in Figure 11. Either multiple source control or the mixer mode can be used to setup the measurements.

The low frequency path is factory characterized using a calibrated low frequency source connected to port 2. If the user desires to perform such a characterization at a different plane (if, for example, a lossy network connected to port 2 is to be included in the receiver cal), this can also be done using the text file format discussed earlier. All that is required is a source (covering the frequency range desired) with a calibrated output power. The test channel reading (for example, b2/1) is then recorded as a function of frequency and stored to the text file. This file is then simply loaded into the instrument prior to measurement.

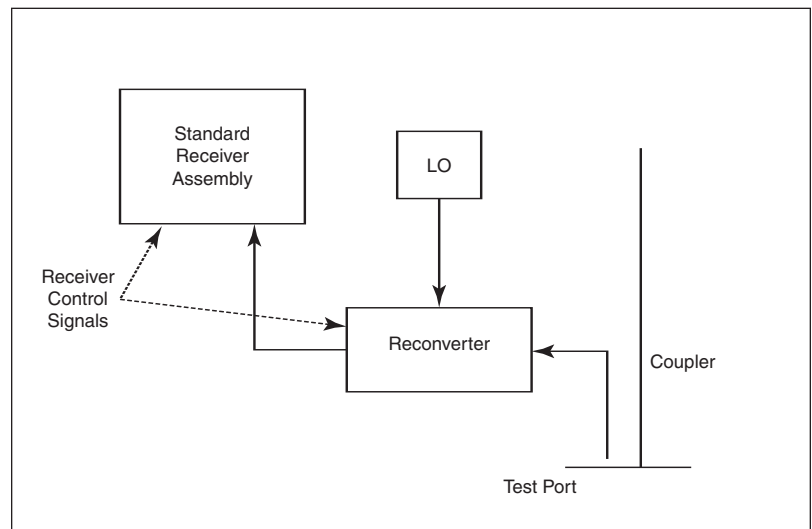

Figure 11. The reconverter special option block diagram is shown here for one receiver path. The reconverter allows test signals (DUT IF outputs) of down to 10 kHz (and sometimes below) to be measured.

# Measurement example: Converter with low IF

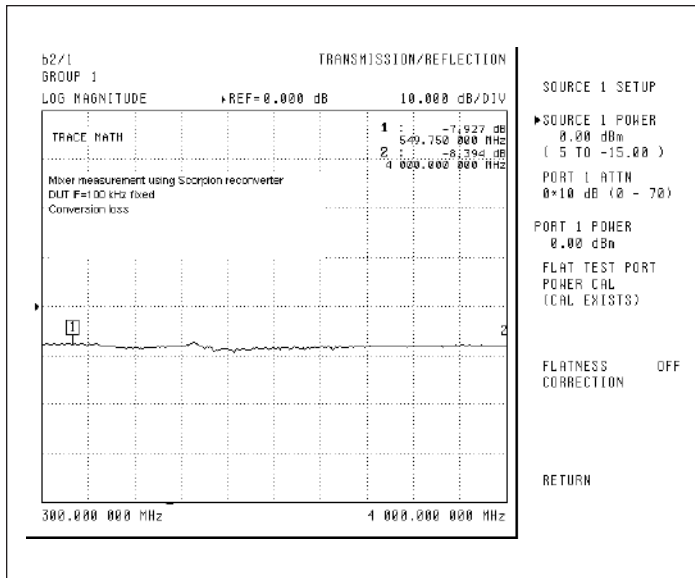

Figure 12. A conversion loss measurement for a fixed DUT IF of 100 kHz is shown here. The internal reconverter option and text-file receiver cal methods were used.

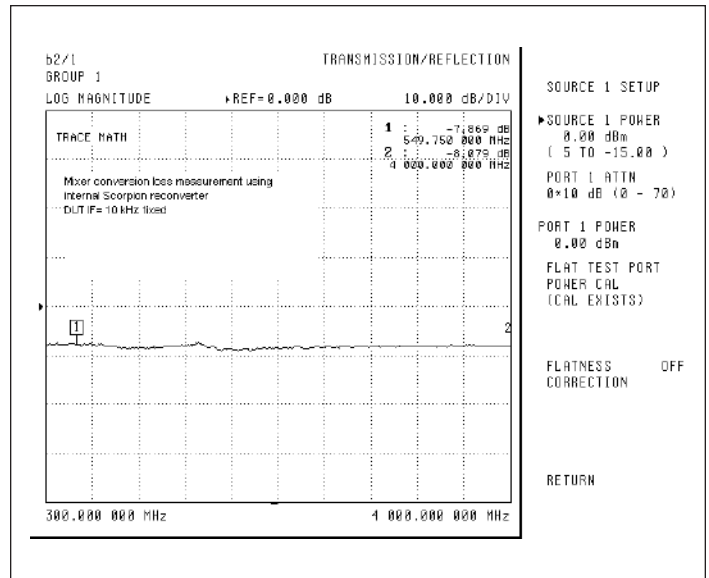

Figure 13. A conversion loss measurement for a fixed DUT IF of 10 kHz is shown here. The internal reconverter option and text-file receiver cal methods were used.

To illustrate this class of measurements, two mixer conversion loss measurements are presented. The IFs are fixed at 100 kHz and 10 kHz in Figures 12 and 13, respectively. A reduced IF bandwidth was used in the second case (100 Hz) as the DUT IF and its image are getting close relative to the standard IF bandwidth. Normalization was done over the RF range of 300-4000 MHz with a conventional receiver calibration applied. In both cases, the measured conversion loss agreed with other measurements (low frequency spectrum analyzer separately calibrated) to within about 0.2 dB.

IMD measurements with these low frequency IFs are also possible. In this example, a fixed DUT LO of 1999.9 MHz was used with tones at 2000 MHz and 2000.03 MHz (30 kHz offset). The IMD products, as shown in Figure 14, were less than -40 dBc as was expected.

At these small offsets, the measurements can be difficult due to phase noise incursions from the sources, heightened ALC communication between the sources, and IF overload effects from having the large tones so near the products. Consult the IMD Application Note (Anritsu part number 11410-00213) for information on mitigating these issues.

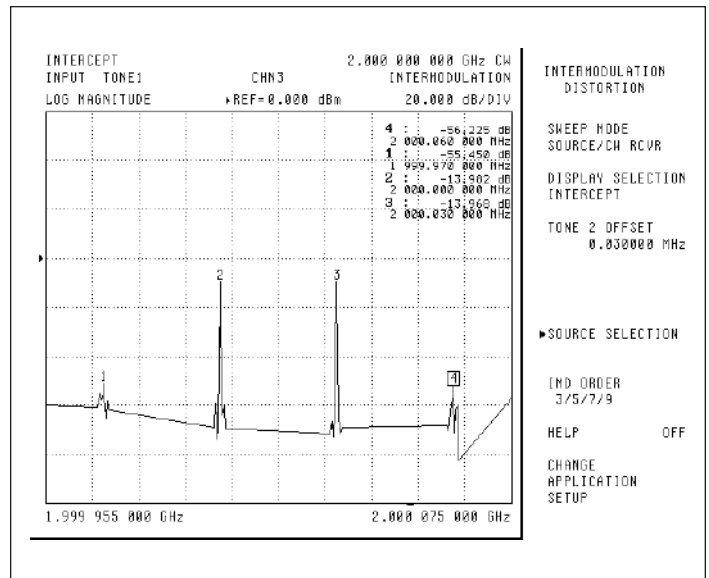

Figure 14. An example low frequency conversion IMD measurement is shown here. The DUT IF is 100 kHz and the tone offset is 30 kHz. Multiple source control or the mixer control panel can be used to setup the measurement.

## SALES CENTERS:

United States (800) ANRITSU  
Canada (800) ANRITSU  
South America 55 (21) 2527-6922

Europe 44 (0) 1582-433433  
Japan 81 (46) 223-1111  
Asia-Pacific (852) 2301-4980

Microwave Measurements Division  
490 Jarvis Drive, Morgan Hill, CA 95037-2809  
<http://www.us.anritsu.com>

